



Installation and User Manual

Read the product description carefully



GREEN

INTERNATIONAL

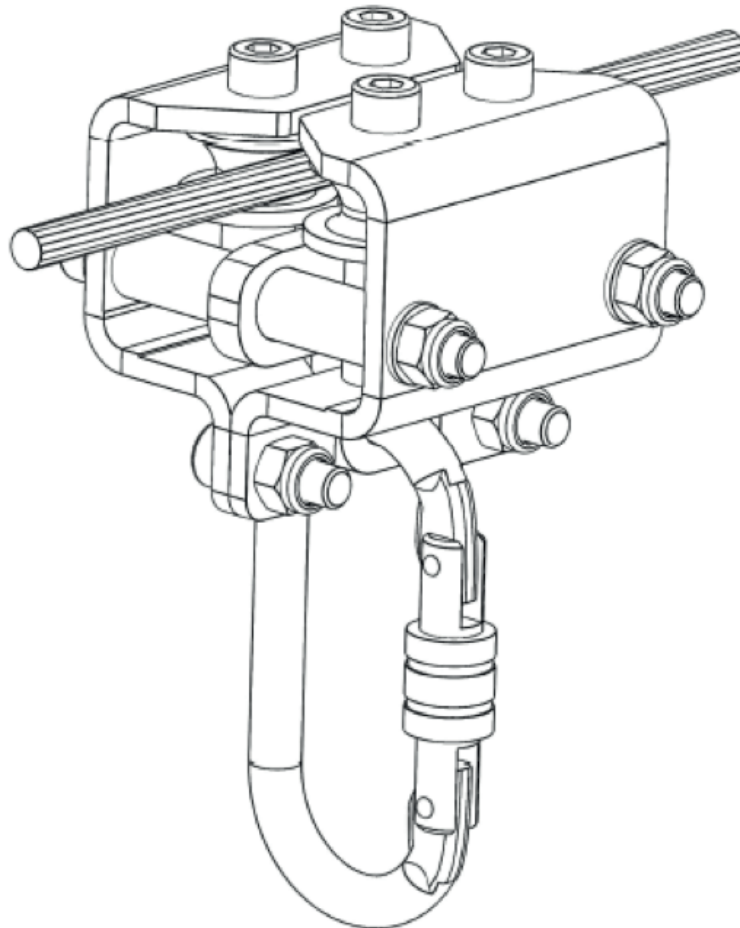

GREENRUNNER 03

ENGLISH

V-20.01.20

DE ACHTUNG

Die Montage und die Verwendung der Sicherungseinrichtung ist erst zulässig, nachdem der Monteur und der Anwender die Original Aufbau- und Verwendungsanleitung in der jeweiligen Landessprache gelesen hat.

EN ATTENTION

Assembling and using of the safety product is only allowed after the assembler and user read the original installation and application instruction in his national language.

FR ATTENTION

Le montage et l'utilisation du dispositif de sécurité ne sont autorisés qu'après lecture par le monteur et par l'utilisateur de la notice d'origine de montage et d'utilisation dans la langue du pays concerné.

IT ATTENZIONE

Il montaggio e l'uso del dispositivo di sicurezza è ammesso soltanto dopo che il montatore e l'utente hanno letto le istruzioni per l'installazione e l'uso nella rispettiva lingua nazionale.

ES ATENCIÓN

No está permitido montar ni usar el dispositivo de protección antes de que el montador y el usuario hayan leído las instrucciones de montaje y uso originales en la lengua del respectivo país.

PT ATENÇÃO

A montagem e o emprego do mecanismo de proteção somente serão permitidos, após o montador e o usuário terem lido as instruções de uso originais, no respectivo idioma do país, sobre a montagem e o emprego do mesmo.

NL ATTENTIE

De montage en het gebruik van de veiligheidsinrichting is pas toegestaan, nadat de monteur en de gebruiker de originele montage en gebruikershandleiding in de desbetreffende taal gelezen hebben.

HU FIGYELEM

A biztonsági berendezés felszerelése és használata csak az után megengedett, miután a szerelést végző és a használó személyek a nemzeti nyelvükre lefordított, eredeti használati utasítást elolvasták és megértették.

SL POZOR

Montaža in uporaba varnostnih naprav je dovoljena šele takrat, ko sta monter in uporabnik prebrala originalna navodila za montažo in uporabo v konkretnem jeziku.

CZ POZOR

Montáž a používání zabezpečovacího zařízení jsou povoleny až poté, co si pracovníci provádějící montáž a uživatelé přečetli v příslušném jazyce originální návod k montáži a používání.

TR DİKKAT

Güvenlik tertibatının montajına ve kullanımına, ancak montaj teknisyeni ve kullanıcı, orijinal kurulum ve kullanma talimatını kendi ülke dilinde okuduktan sonra, izin verilir.

NO OBS

Monteringen og anvendelsen av sikkerhetsinnretningene er gyldige først etter at montøren og brukeren har lest den originale oppbygnings- og bruksanvisningen i det tilsvarende landets språk.

SV OBS

Säkerhetsanordningen får inte monteras och användas förrän montören och användaren har läst igenom konstruktionsbeskrivningen och bruksanvisningen i original på resp lands språk.

FI HUOMIO

Turvalaitteiden asennus ja käyttö on sallittu vasta, kun asentaja ja käyttäjä ovat lukeneet alkuperäisen asennus- ja käyttöohjeen omalla kielellään.

DA GIV AGT

Montagen og brugen af sikkerhedsudstyret er først tilladt, efter at montøren og brugeren har læst den originale vejledning i samling og brug på det pågældende lands sprog.

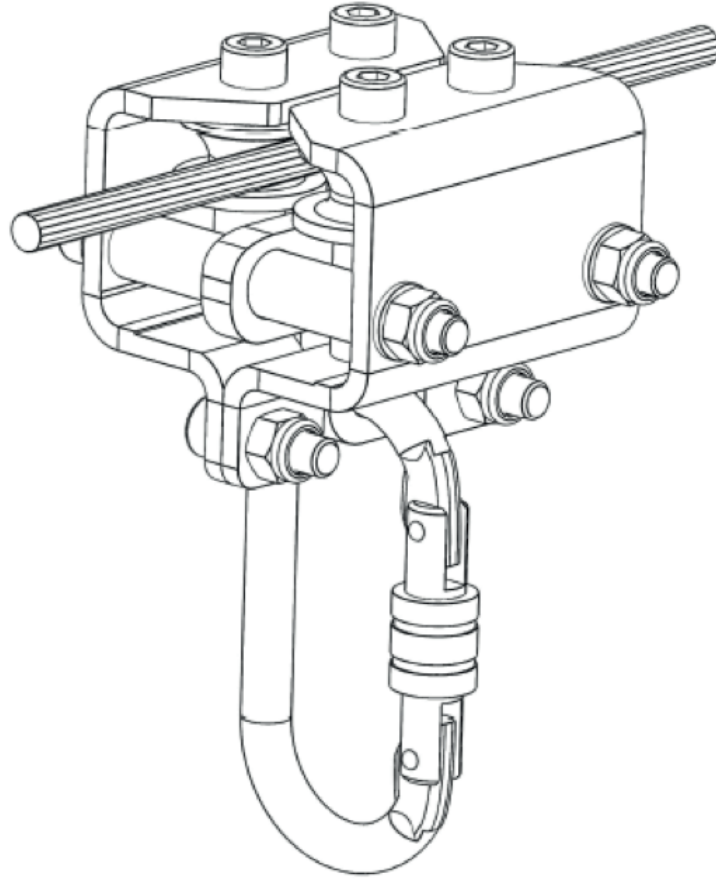

© GREEN International Absturzicherungs GmbH, subject to errors, printing errors, and the right for technical changes is reserved!

PROJECT DATA

SYSTEM DESCRIPTION

INSTALLATION COMPANY

Table of contents:

1. General safety instructions	5
1.1. Inspection before use	6
1.2. Warranty	6
1.3. Application and approval	6
1.4. Maintenance / Storage / Disposal	6
1.5. Control / Recurring inspections	6
2. Assembly	7
3. Dimensions	8
3.1. Compatible equipment	8
3.2. Identification	8
4. Acceptance point for the anchorage device	9
5. Inspection protocol	9
6. Assembly protocol	10
7. Control card	11

1. General safety instructions

- Before assembly / application, the installation / operating instructions must be carefully read in the local language and understood, otherwise the anchorage system must not be installed or used.
- The local safety regulations must be respected in any case, or the installer / user must be familiar with these (trained).
- The safety systems may be assembled or used only by a professional / specialist familiar with the system (latest technology). (PPE briefing absolutely necessary), the respective accident prevention regulations must be observed.
- In case of any uncertainty during assembly, the manufacturer shall be contacted immediately.
- Before installation or start of use, a rescue plan must be created based on the object (e.g. where can I get help, how do I get the accident's victim as quickly as possible off from the roof or, in case of fall, from the rope). Work on roofs must be performed by min. 2 persons. 2. Person to be able to initiate rescue operations.
- Before the safety system is used, it must be checked by means of a visual inspection for obvious defects, such as: loose screw connections, faulty seals, deformation, corrosion, wear, etc.
- When working on exposed sites (e.g. in height, on roofs, etc.), security is limited, or cannot be guaranteed under the influence of drugs, physical and mental impairment, alcohol abuse, cardiovascular problems, etc.
- The safety device must only be used as a personal security device, do not thread or attach any undefined loads.
- This anchorage point is a single anchorage point approved for max.1 person.
- The Greenrunner is only suitable for people and not for loads.
- It may be used for Greenline safety rope systems only for rope runners authorized by us (GREEN International Absturzsicherungs GmbH) such as Greenrunner 03.
- The Greenrunner is to be used exclusively with one of the carabiners supplied by us according to EN 362.
- The anchorage device may be used only in conjunction with a personal protective equipment according to EN 361 (safety harness) and EN 363 (fall arrest system).
- After a fall case, the anchorage device must be locked and taken out of use immediately, and the manufacturer must be contacted without delay. If there are doubts as to the correct function of the anchorage device, it must be taken out of service immediately and returned to the manufacturer.
- The anchorage device may be exposed to corrosive materials or chemicals. If the anchorage device is made of stainless steel, it must not be contacted to metal dust or steel tools, as there is a risk of corrosion.
- Before commencing work, measures must be taken to ensure that no objects (e.g. tools, roofing elements, anchorage devices, etc.) can fall down from the workstation. Keep sidewalks or underlying areas clear and closed-off.
- The anchorage device should be designed, used and applied so that a fall can be avoided on the roof edge. (When planning, definitely consider building heights and details of the PPE to be used)
- For horizontal use, only fasteners are suitable that are approved, tested and also edge tested according to the latest technology. Height safety devices must be specially approved according to EN 360.
- The safety system, including personal protective equipment must be subjected to a test by an expert at least once a year before each use for visible damage (definitely comply with the manufacturer's instructions, as special circumstances may shorten the inspection interval).
- The verification by a qualified person shall be recorded in the test book / test document. Visual inspection of the anchorage device for obvious defects and legibility of the manufacturer's instructions. Basis of the annual inspection is the acceptance protocol and the current product description. (If in doubt, contact the manufacturer).
- No structural modifications such as deliberate deformation, cutting, drilling holes, deviation from the manufacturer's specifications, etc. are allowed, disclaimer by the manufacturer.
- Upon transfer of the anchorage device to external contractors, the original (latest edition) of the installation and operating instructions must be handed over in writing.
- The installers must ensure that the substructure is suitable for the installation of the anchorage device. In case of doubt, a structural engineer must be consulted.
- The anchorage device is designed for loading in all directions parallel or perpendicular to the mounting surface.
- The professional installation of the anchorage device must be documented by an installation protocol and in case of a non-visible fastening, with a photo documentation. (E.g. anchorage devices which are permanently covered / sealed).
- Stainless steel bolts must be greased with a suitable lubricant.
- If wind speeds exceed the usual extent, stop using the anchorage device.
- In case of sloping roofs, in addition to the anchorage device a suitable snow guard must be fitted in order to prevent deformation of the anchorage device.
- Attention: Snow clearance at the facility required due to snow pressure load.

- When designing the anchorage device, always consider the free space below the drop height (min. 1 meter). It is also necessary to take into account the fall height, the deformation of the anchorage device, the rope deflection, and the manufacturer's data of the PPE to be used. (Tearing open the fall absorber, shifting of the harness on the body, lengthening of the rope)
- When accessing the safety system, the positions of the anchorage devices (plan or sketch of roof top view with dimensions) are to be documented (see the last page of this product description).

1.1. Inspection before use

- Read the product description carefully
- Carefully read the instructions of the personal protective equipment to be used.
- Check the anchorage device for damage (deformation, corrosion, tight fit, bolts tightened, labeling exists, inspect for visible defects).
- The anchorage device must not be used if these criteria are not met.

1.2. Warranty

Warranty period is 2 years from the subscription / purchase date. The warranty applies to the construction and manufactured parts that are subject to appropriate use and are not misused. The warranty period is shortened if no normal weather and operating conditions prevail (chemical, corrosive conditions).

In case of loading, the warranty expires on all parts subject to stress

1.3. Application and approval

The Greenrunner 03 is a movable anchorage point for 1 person and part of the "Greenline" horizontal anchorage system and allows a complete traversing of the rope system, (assuming there are mobile intermediate rope brackets and curve elements installed in the system).

1.4. Maintenance / Storage / Disposal

The Greenrunner 03 must be stored in a dry, ice-free, grease-free state. Ideally, it should be stored with the PPE in a PPE cabinet placed next to the roof hatch. When disposing, the Greenrunner shall be correctly transported to a material recycling site (and not thrown in the household waste)

1.5. Control / Recurring inspections

The Greenrunner 03 shall be subjected to a check for visible defects before each use (deformation, locking mechanism, obvious damage, restricted functioning). If the gap of 3.7 mm (see dimensions) is exceeded, the Greenrunner 03 must be replaced.

The Greenrunner 03 must undergo an annual inspection by a specialist/expert certified by GREEN International Absturzschutz GmbH. Testing intervals are shown in the inspection logbook. The test result must be documented in the inspection logbook. In case of any failures found, the Greenrunner 03 shall be withdrawn from use immediately and the manufacturer must be contacted without delay.

2. Assembly

Open Greenrunner 03 and connect the two spacer sleeves with the eyelet. Preassemble together with the housing halves and the M8 x 25 cylinder head bolts. Screw the bolts so far only as to allow sufficient clearance for mounting on the stainless steel rope. Then install the Greenrunner 03 on the stainless steel rope and pre-fasten with the M8 x 95 cylinder head bolts. It must be noted that washers were enclosed on both sides, both for the bolt heads and the nuts! Now tighten all the bolts, start with the M8 x 25 bolts! It is important that the marked surfaces are always aligned and the gap of 3.7 mm is not exceeded!

Tightening torque for the M8 bolts approximately 14 Nm

3.7 mm gap size

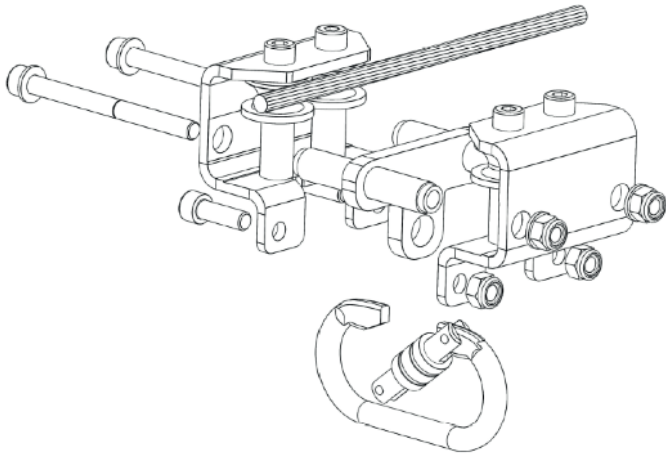

The surfaces must be aligned with each other!

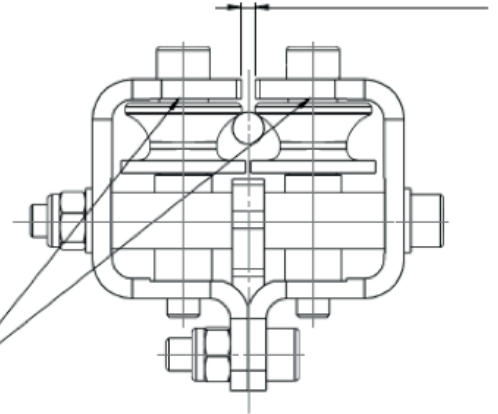

- Then attach the carabiner and prepare for use.

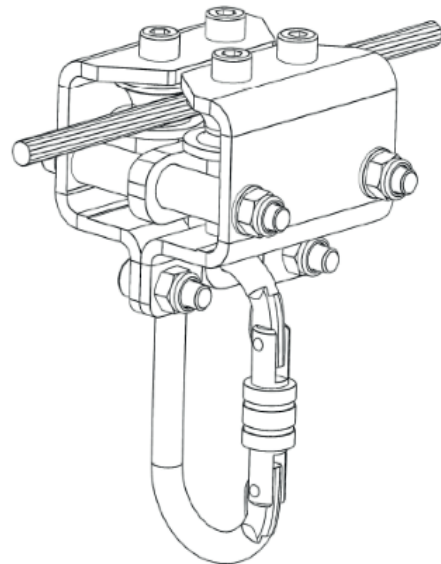
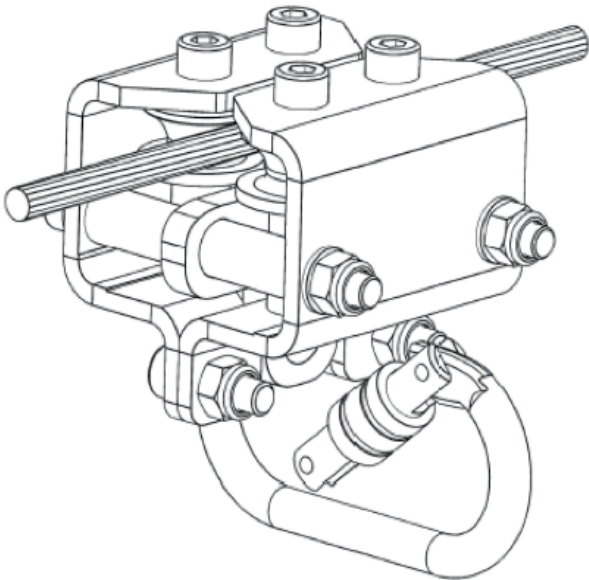

3. Dimensions

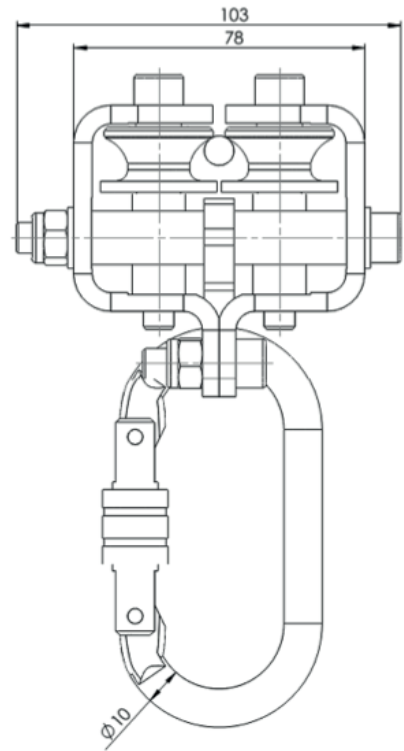
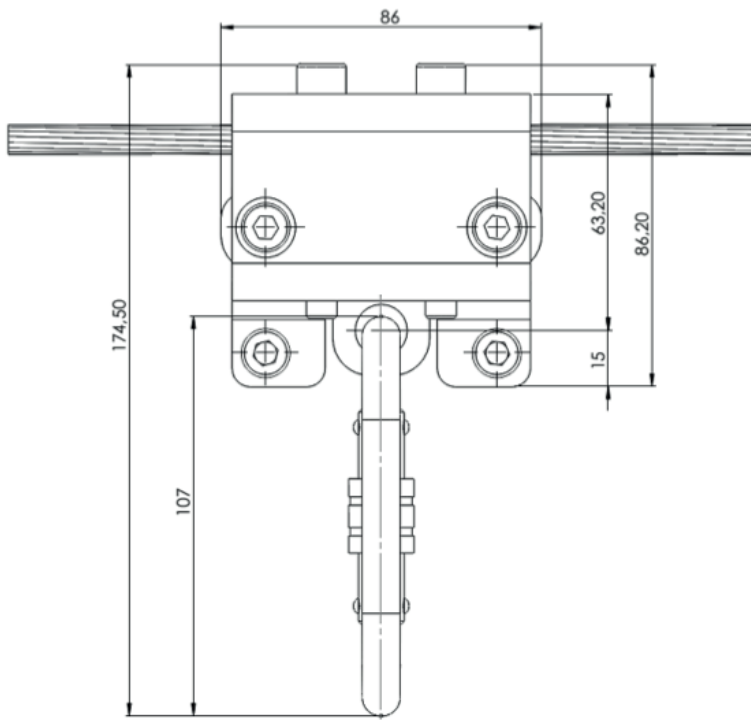

3.1. Compatible equipment

The anchorage device may be used only in connection with fastening elements in accordance with EN 362 and a personal fall protection equipment, e.g. fasteners with shock absorber according to EN 354 and EN 355, guided type fall arrester including a moveable guide in accordance with EN 353 2 or height safety device according to EN 360 (height safety device with horizontal approval).

Basically, and especially in a restraining system with a rope shortener, the fasteners must be set so that a fall is not possible.

3.2. Identification

Type identification	GREENRUNNER 03	
Name of distributor	GREEN International Absturzschutz GmbH	
Year of manufacture / KW	XXXX/XX	
Test standards, CE marking	EN 795:2012 C	
Max. permitted number of persons	1	
Symbol to indicate that the instruction manual must be read		CE marking Identification number of the Certification Authority TÜV Austria

Certification:

The GREENRUNNER 03 is tested / tested and certified according to EN 795: 2012 C.



4. Acceptance point for the anchorage device



TÜV AUSTRIA SERVICES GMBH
Deutschstraße 10
1230 Wien

If the anchorage devices are distributed in countries with different languages, request from GREEN International Absturzschutz GmbH without delay to provide the installation and operating instructions in the local language.

5. Inspection protocol

In the annual review the following check points must be verified:

Presence of the installation and operating manuals, acceptance report, fastening / photo documentation, inspection log. Based on these documents (in compliance with the information in the installation manual), the proper installation can be confirmed.

A visual inspection for obvious defects must be performed. This includes, among others:

Check for tight fit, corrosion, water ingress into the static load-bearing structure (tightness), deformation of the safety device, correct tightening of bolts (torque).

Year of manufacture:	Type. GREENRUNNER 03 EN 795:2012 C
Date of purchase:	Calendar week:
Date of first use:	Reviewer:

Date	Reason for the review	Identified defects	Name and signature of expert	Date of the next review

© GREEN International Absturzschutz GmbH, subject to errors, printing errors, and the right for technical changes is reserved!

7. Control card

Performed activities	Identified Defects		Date	Company / name / Expert	Description of defect / Activities	Date of the next scheduled review
	Yes	No				
<p>System review</p> <ul style="list-style-type: none"> • No deformation of the individual parts recognizable • all screws and connections tight • Rope guides undamaged <p>Visual inspection of the attachment points and accessories (fasteners, etc.) by an authorized expert.</p>						

© GREEN International Absturzicherungs GmbH, subject to errors, printing errors, and the right for technical changes is reserved!

*** In the event of a fall or in case of doubt, the anchorage device shall be withdrawn immediately from use and sent to the manufacturer or a specialized workshop for inspection and repair. This also applies to damage to the slings.

The document must be completed by the person in charge and kept in a safe place together with the instructions for use (e.g. property management)

When accessing the roof safety system, the positions of the anchorage devices are to be documented in plans (e.g. a sketch of the roof-top view)!



GREEN International Absturzsicherungs GmbH

Fabriksplatz 1/10, 4662 Steyrermühl

Tel.: +43 7613 32498-0

Fax: +43 7613 32498-16

office@green-gmbh.at

www.green-international.at